

KVN DN 65-150

Flange design

GENERAL FEATURES

- » Piston valve with bore
- » Sealing via two elastic KX-GT valve rings
- » Excellent control characteristics
- » Fire Safe
- » Special regulating design available (KVRLN)

CONNECTIONS

Flange in accordance with EN 1092-2 (Mat. code III)

DIMENSIONS

EN 558-1, GR. 1

ACCEPTANCE TESTING

- » Seat leak tightness: EN 12266-1 P12, leakage rate A
- » Tightness to atmosphere: EN 12266-1 P11
- » Strength: EN 12266-1 P10

TEMPERATURE

-10 °C to +300 °C (see P-T diagram)

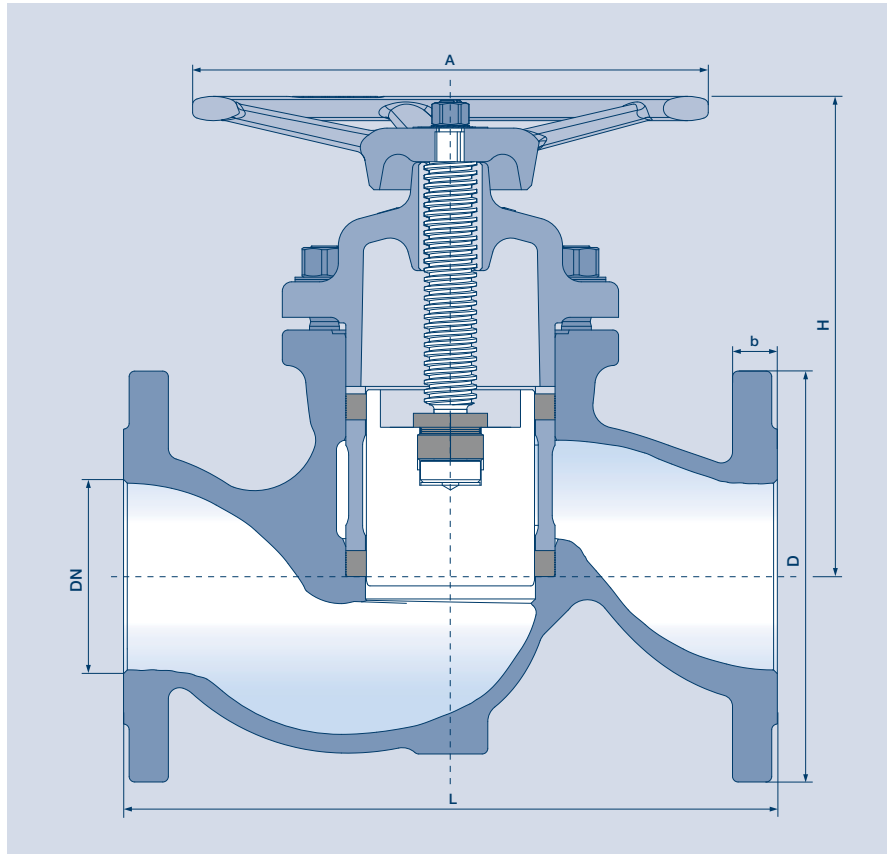

KVN FLANGE DESIGN DN 65-150

MATERIAL

- » Grey cast iron EN-GJL-250 / 5.1301 (Material code III)

DN	Dimensions						PN	Weight
	L	H	A	D	b	Hub	III	in kg
65	290	189	250	185	20	50	16	23
80	310	214	250	200	22	58	16	30
100	350	257	280	220	24	75	16	43
125	400	298	400	250	26	86	16	69
150	480	328	400	285	26	98	16	96.5